

Aranet 4-20 mA transmitter with 24 VDC power supply

Battery-powered and energy-efficient solution designed to integrate with any 3rd party sensor

Aranet 4-20 mA transmitter with 24 VDC power supply

Measures analog signal of a 3rd party sensor, provides 24 VDC power for a 3rd party sensor.

TDSCT202 (EU)
TDSCT2U2 (US, AS)

Sensor performance

Range	0 – 30 mA
Resolution	0.01 mA
Accuracy ¹	± 5 %
Output voltage	24 VDC
Output voltage tolerance	± 0.6 VDC
Max output power	2.8 W

Radio parameters

Line of sight range	3 km (1.9 mi)
Supported ISM bands	EU868, RU869 US920, AS923
Transmitter power	14 dBm
Data transmission interval	1, 2, 5 or 10 minutes
Data protection	XXTEA encryption

General

Ingress protection rating	IP67
Operating temperature range ²	-30 °C to 85 °C (-22 °F to 185 °F)
Dimensions	160 x 132 x 46 mm (6.3 x 5.2 x 1.8 in)
Weight	250 g (8.8 oz)
Enclosure material	Polycarbonate
Included in the box	1 AA alkaline battery

Power

Input voltage	85 – 265 VAC
Frequency range	47 – 63 Hz
Max power consumption	10 W

Compliance

CE	Conformité Européenne
IC	Innovation, Science and Economic Development Canada
FCC	Federal Communications Commission (USA)

¹ 95 % of the sensors measure within these typical limits in equilibrium state at the time of sale.

² If battery used, operating temperature range narrows according to battery type. For alkaline battery the range is -20 °C to 50 °C (-4 °F to 122 °F).



Ihr Aranet Partner:

C+R Automations- GmbH
Nürnberger Straße 45
90513 Zirndorf

Tel. +49 (0)911 656587-0
info@crautomation.de
www.crautomation.de

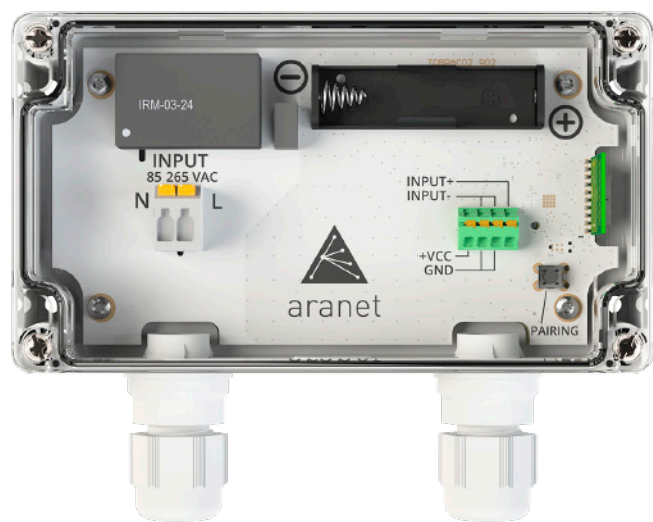

Aranet 0-10 V transmitter with 24 VDC power supply

Battery-powered and energy-efficient solution designed to integrate with any 3rd party sensor

Aranet 0-10 V transmitter with 24 VDC power supply

Measures analog signal of a 3rd party sensor,
provides 24 VDC power for a 3rd party sensor.

TDSVT202 (EU)
TDSVT2U2 (US, AS)

Sensor performance

Range	-32 to +32 VDC
Resolution	0.01 V
Accuracy ¹	± 5 %
Output voltage	24 VDC
Output voltage tolerance	± 0.6 VDC
Max output power	2.8 W

Radio parameters

Line of sight range	3 km (1.9 mi)
Supported ISM bands	EU868, RU869 US920, AS923
Transmitter power	14 dBm
Data transmission interval	1, 2, 5 or 10 minutes
Data protection	XXTEA encryption

General

Ingress protection rating	IP67
Operating temperature range ²	-30 °C to 85 °C (-22 °F to 185 °F)
Dimensions	160 x 132 x 46 mm (6.3 x 5.2 x 1.8 in)
Weight	250 g (8.8 oz)
Enclosure material	Polycarbonate
Included in the box	1 AA alkaline battery

Power

Input voltage	85 – 265 VAC
Frequency range	47 – 63 Hz
Max power consumption	10 W

Compliance

CE	Conformité Européenne
IC	Innovation, Science and Economic Development Canada
FCC	Federal Communications Commission (USA)

¹ 95 % of the sensors measure within these typical limits in equilibrium state at the time of sale.

² If battery used, operating temperature range narrows according to battery type. For alkaline battery the range is -20 °C to 50 °C (-4 °F to 122 °F).



Ihr Aranet Partner:

C+R Automations- GmbH
Nürnberger Straße 45
90513 Zirndorf

Tel. +49 (0)911 656587-0
info@crautomation.de
www.crautomation.de



Aranet

transmitters with

power supply

user guide

Discover what type of transmitters there are, and how to connect and pair them with the base station.

2022-11-09

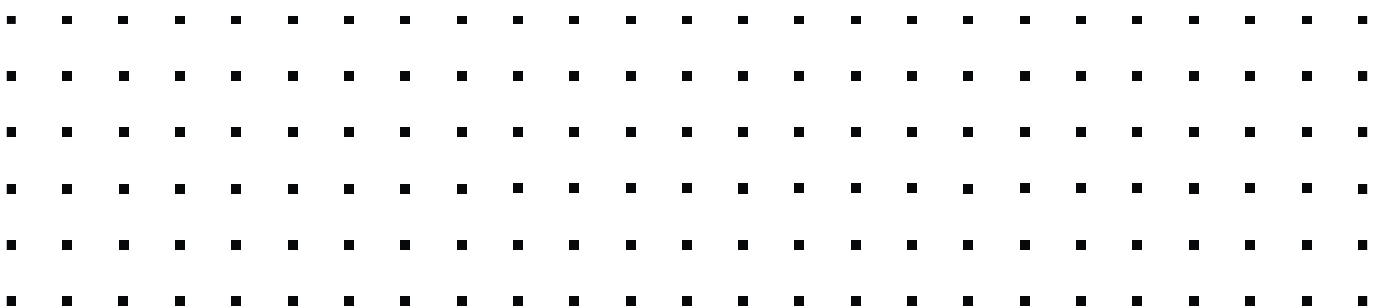

About the transmitters

Aranet offers four different transmitters that can be connected with third-party sensors and thus integrated into the Aranet ecosystem. Transmitters themselves are battery-powered, but can also be connected to mains electricity to power the third-party sensor.

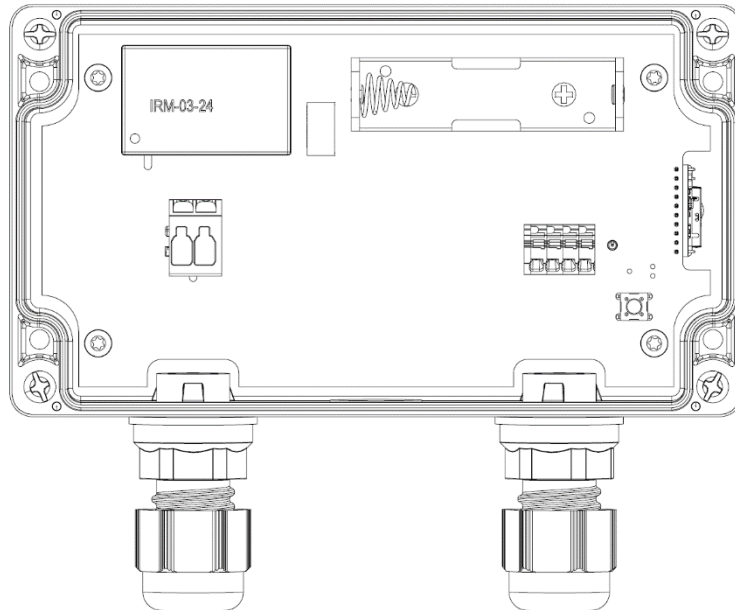

Visual 1: Aranet transmitter

- **[Aranet 4 – 20 mA transmitter with 12 VDC power supply \(datasheet\)](#)**
- **[Aranet 4 – 20 mA transmitter with 24 VDC power supply \(datasheet\)](#)**
- **[Aranet 0 – 10 V transmitter with 12 VDC power supply \(datasheet\)](#)**
- **[Aranet 0 – 10 V transmitter with 24 VDC power supply \(datasheet\)](#)**

Pairing the transmitter with the base station

Things to know before starting the pairing procedure:

- It is possible to pair the transmitter to the base station with or without the sensor connected.
- To pair the transmitter, the transmitter must be near the base station (max 20 m).
- When installing and placing the sensor note that the cable must be routed in a manner to obtain a “water/drip loop” for water to drop off. Do not stress the cable.
- If you experience any difficulties, get in touch with support@aranet.com.

Option 1: How to pair the transmitter to the base station with batteries (recommended)

Pairing the sensor with the battery ensures an interrupted signal to the base station during the whole installation process, as well as in case of an electricity outage or sensing element failure.

1. Have the transmitter and 1x AA battery ready.
2. Unscrew and take off the transmitter’s lid.
3. Open the Sensorhub application (ensure that you have the latest firmware upgrade).
4. Open the section “SENSORS” and there choose the preferable measurement interval.
5. Click the “PAIR SENSOR” button on the computer screen and then immediately insert the batteries or insert batteries and click the “PAIRING” button on the transmitter (left corner).
6. The sensor will be paired and appear in the category “SENSORS”.
7. You can finish your sensor setup and screw the lid back.

Option 2: How to pair the transmitter to the base station with mains power, without batteries

1. Connect the power cable to the transmitter.
2. Unscrew and take off the transmitter's lid.
3. Connect it to the power mains.
4. Open the Sensorhub application (ensure that you have the latest firmware upgrade).
5. Open the section "SENSORS" and there choose the preferable measurement interval.
6. Click the "PAIR SENSOR" button on the computer screen and then click the "PAIRING" button on the transmitter (left corner).
7. The sensor will be paired and appear in the category "SENSORS".
8. You can finish your sensor setup and screw the lid back.

Connection to mains power	Cables
N – Neutral	Blue
L – Live	Brown
GND*	Green/yellow

*The wire should be clipped at the end.

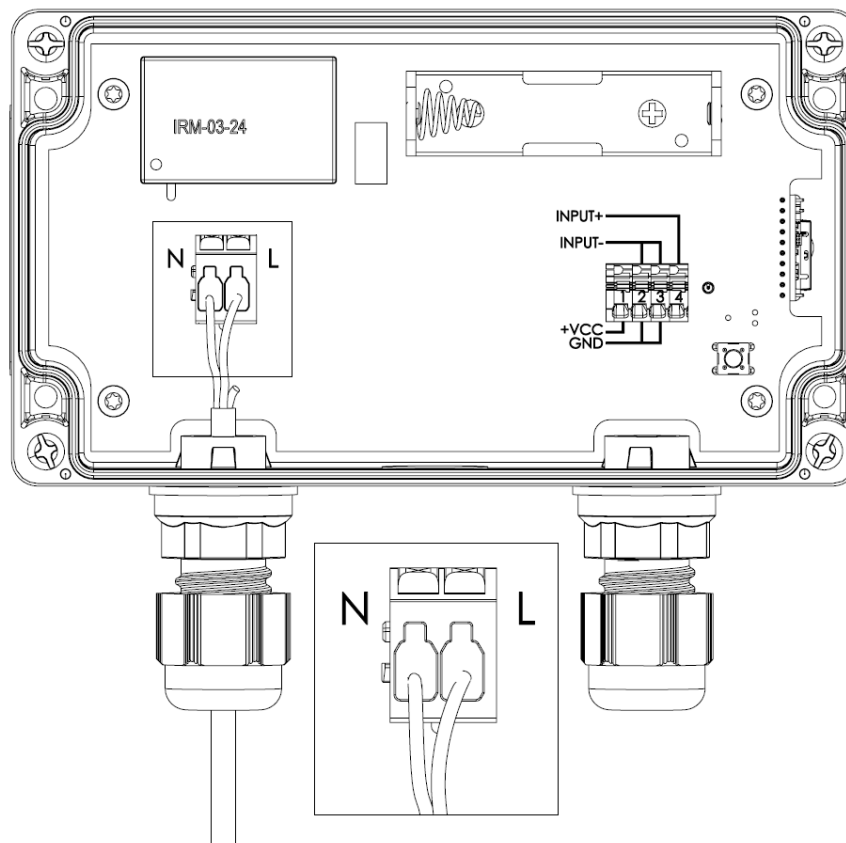

Visual 2: Connecting power cable to the transmitter

Finishing up the installation of the transmitter

If needed, the sensor can be either placed on a clean surface or attached to a wall.

1. Unscrew the transparent lid of the transmitter.
2. To attach the transmitter to a wall use the 4 mount holes in each corner of the body transmitter.
3. Screw the transmitter to the wall.
4. Attach the transparent lid back.